

Clutch Disc Check

Special Tool(s)

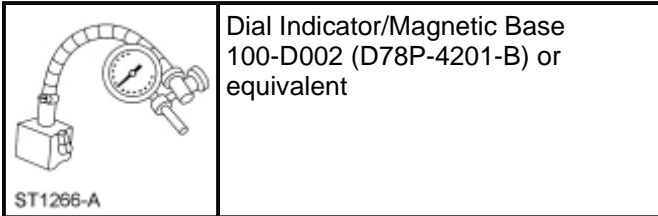

NOTE: The 5.4L application is an assembly of discs and plates. It is serviced as an assembly only.

1. Check the clutch disc for the following conditions. Install a new clutch disc as necessary.
 - Lining surface for hardening
 - Presence of oil
 - Loose clutch disc lining rivet
 - Cracking, scoring or other surface marks
 - Use an emery cloth to remove minor imperfections in the clutch disc lining surface
 - Discoloration

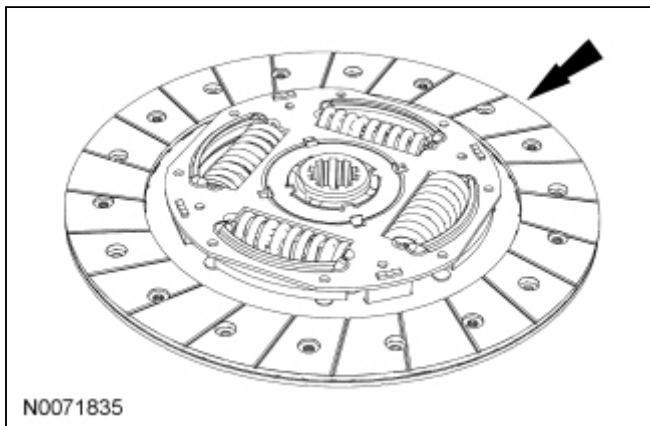

2. Check for a worn clutch disc lining. Measure the minimum allowable depth to the rivet heads with a slide caliper. Install a new clutch disc as necessary.

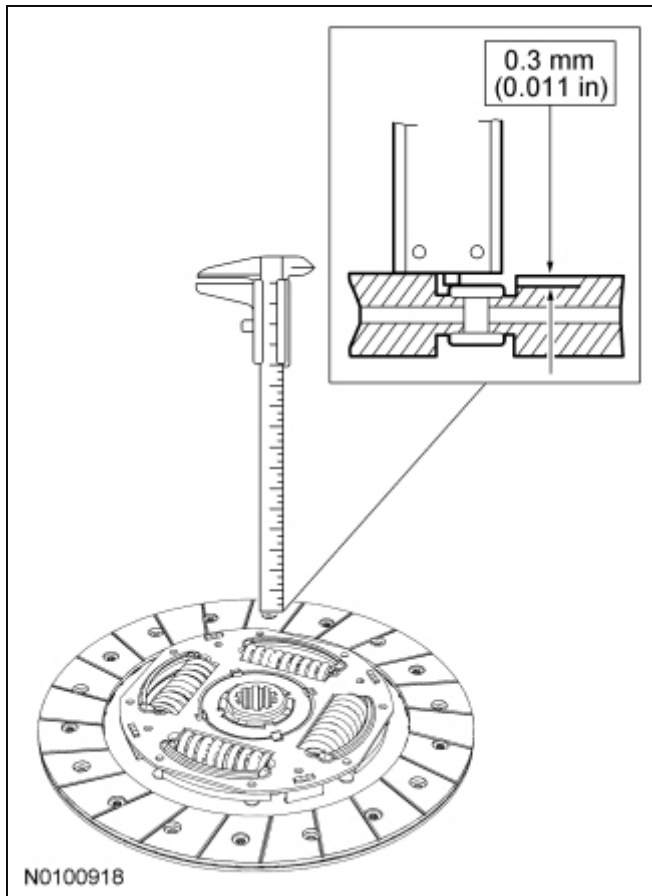

3. Using a suitable lathe and a Dial Indicator/Magnetic Base, check the maximum allowable runout of the clutch disc. Install a new clutch disc as necessary.

